



## A BACKGROUND OF VARIABLE COMPRESION RATIO ENGINES

Bogdan MĂNESCU<sup>1\*</sup>, Ionuț DRAGOMIR<sup>1</sup>, Nicolae-Doru STĂNESCU<sup>2</sup>

<sup>1</sup>AKKA ROMSERV, <sup>2</sup>University of Pitești

*Article history:*

*Received: 05.03.2016; Accepted: 07.04.2016.*

**Abstract:** *Increasing the efficiency of an internal combustion engine for new environment requirements can be achieved by using a variable compression ratio engine. Using this type of engine, it is possible to obtain a higher efficiency at partial loads for urban driving. A high compression ratio over 15:1 increases engine thermodynamic efficiency and provides a better fuel consumption. In this paper are described various technical solutions to obtain a variable compression ratio.*

**Keywords:** Internal combustion engine, variable compression ratio

### INTRODUCTION

Compression ratio of an engine is the value that represents the ratio of the volume its combustion chamber from the largest capacity to its smallest one. A high compression ratio is desirable because it extracts more energy from a given mass of air-fuel mixture due to the higher thermal efficiency. First modern spark ignition engine designed by Nicolaus Otto in 1876 has a 2.5:1 compression ratio. Compression ratio for a gasoline engine is limited one hand by materials used and on the other hand by knocking occurrence that can destroy the engine. The compression ratio for a usual petrol power engine is not higher than 10:1. Some engines used for high performance cars from 1955-1972 allow compression ratios high as 13:1. A method to prevent knock is 'swirl' engine that forces intake charge to adopt a fast circular rotation during compression stroke that provides quicker and more complete combustion [1]. First VCR engine was built by Harry Ricardo in 1920s. This work led him devising the octane rating system and is still in use today.

### VCR ADVANTAGES

With a VCR engine one can increase fuel efficiency under varying loads. Higher loads require lower ratios to be more efficient and vice versa. Gasoline engines have a limit on the maximum pressure during compression stroke, after the air/fuel mixture detonates. To obtain more power, more fuel must be burden into cylinder and more air is needed. With the aid from a turbocharger or supercharges more air is introduced into cylinder. This would result appearance of knocking phenomenon unless compression ratio is decreased. Disadvantage of this at partial loads engine efficiency is lower with lack of power and torque. The solution is to be able to vary the inlet pressure and adjust the compression ratio to obtain benefits for all engine speeds and loads. Variable compression ratio is a way to achieve fuel economy and new environment regulations according CO<sub>2</sub> emissions. A VCR engine can use various fuels as ethanol or LPG [2].

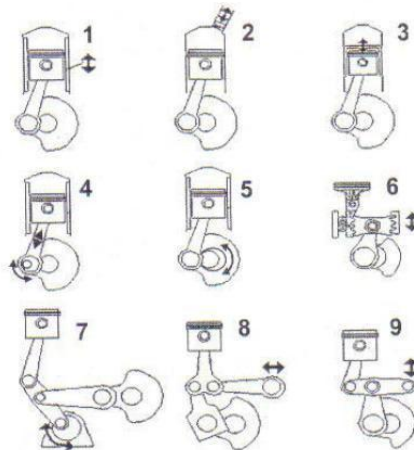
### METHODS TO OBTAIN VCR

Obtaining variable compression ratio can be made by redesigning engine elements. Most widespread methods are presented in Figure 1.

\*Corresponding author: bogdan.manescu04@gmail.com

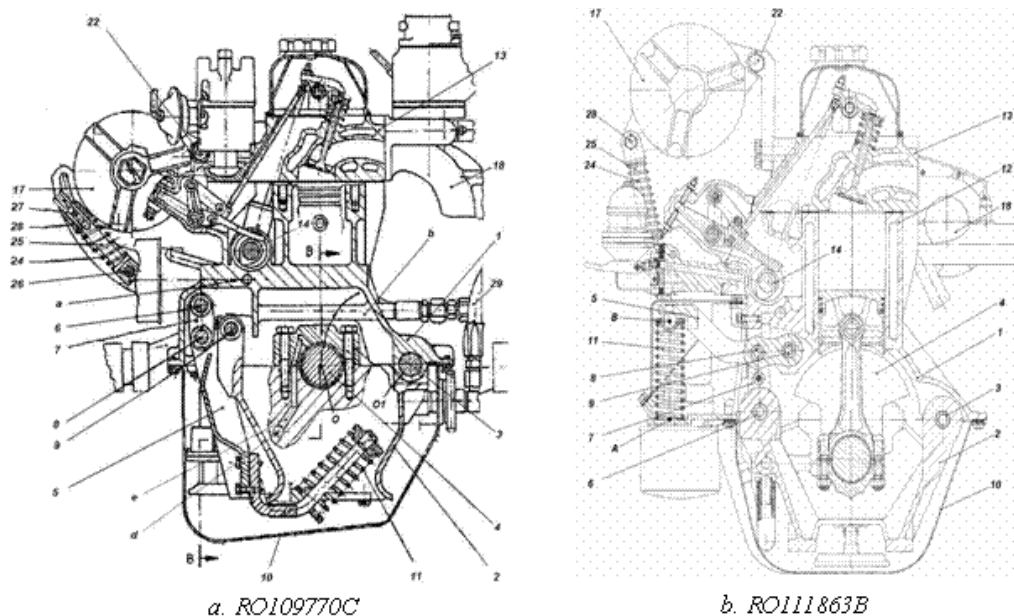
In the figure, the notations are as follows:

1. articulated engine block;
2. modifications of combustion chamber volume by adding supplementary volume;
3. changes of piston geometry;
4. road attached eccentric regarding crankshaft or variable length road;
5. eccentric mounted crankshaft;
6. crank road mechanism with gears;
7. articulated rods with additional connection between road and crankshaft [3];
8. articulated rods with additional connection between road and crankshaft [3];
9. articulated rods with additional connection between road and crankshaft [3]



**Figure 1.** Methods to obtain VCR engines [3]

## ARTICULATED ENGINE BLOCK



**Figure 2.** Examples of two patented Hara methods to obtain a VCR engine [5]

A type of an articulated engine block engine is the Hara engine developed by professor Hara from University of Pitesti. Professor Hara's research leads to registering several patents numbers 111863B, 109770C, 104027, 96876, in Romania. The maximum compression ratio

12.5:1 obtained at the idle speed; when the engine load increases, the upper part of the engine is moving and the volume of combustion chamber increases, while the compression ratio decreases down to 8.5:1 at full load. Regulation of compression ratio is self-made by the level of cylinder pressure. This type of engine keeps an unmodified combustion chamber and a several series parts [4].

Another articulated engine block engine is SAAB SVC engine [6]. The 5 cylinder 1.6l engine has a performance of 225 HP. In order to reach high specific power and torque, a combination of variable compression ratio and high pressure charging is used. The engine performances are similar to a larger engine reached into good fuel consumption. SVC engine uses a supercharger instead of a turbocharger to achieve these performances. VCR system enables compression ratios up to 14:1 during part load operation. Engine parameters are presented in the Table below [6].

**Table 1.** Engine parameters

Cylinders	-	5 in line
Cylinder volume	cm <sup>3</sup>	1598
Bore / Stroke	mm	66 / 88
Firing order	-	1-2-4-5-3
Max power @ rpm	kW	165 @ 5000
Max torque @ rpm	Nm	305 @ 4000
Compression ratio	-	8:1 - 14:1
Valve train	-	DOHC / 4 Valve
Charging system	-	Screw type SC
Engine managem.	-	Saab Trionic 7
Emission control	-	TWC
Emission target	-	ULEV II

The SVC engine's cylinder block is divided into two parts. The lower part is the crankcase, where crankshaft, con-rods, pistons etc. are mounted. The upper part is what SAAB calls the "Monohead", is where the combustion chamber, valves, cylinder liners etc. are situated. The Monohead can be tilted relative to the crankcase through a pivot shaft. The pivot shaft location is a compromise between the previous requirements avoiding too much cylinder axial variation and keeping the engine width down. Tilting of the Monohead (enabling the variation of the CR) is controlled by a device which is called the eccentric shaft mechanism by SAAB. The eccentric shaft is turned to the chosen position by a hydraulic actuator situated at the front of the engine. A sensor indicates the position of the eccentric shaft and thereby the actual CR. A separate hydraulic system supplies hydraulic pressure between 60 – 100 bars to the hydraulic actuator [6].

## MODIFICATIONS OF COMBUSTION CHAMBER

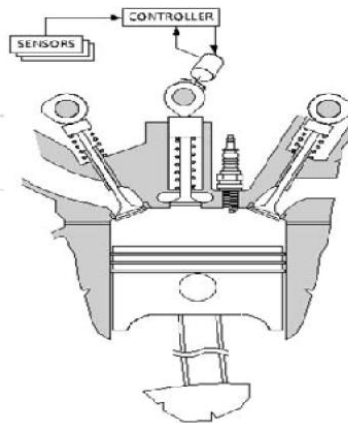
Ford patented a method to modify combustion chamber volume by using a secondary piston. With piston move is created optimum compression ratio according to engine load. The volume of combustion chamber is increased to reduce the compression ratio by moving

secondary piston with communicates with combustion chamber. The cylinder head cooling needs to be improved and the auxiliary piston needs proper lubrication [7].

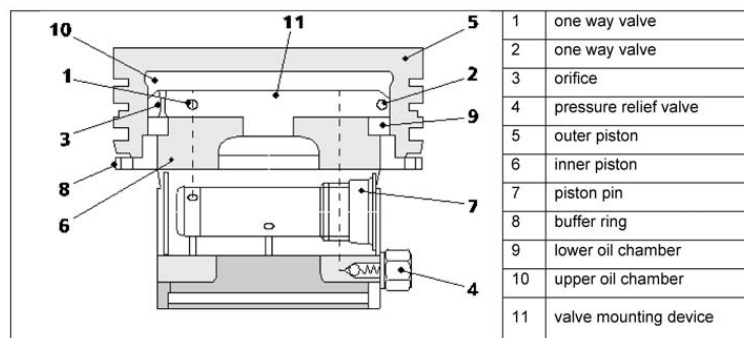


**Figure 3.** Eccentric shaft mechanism controls the CR [6]

### CHANGES OF PISTON GEOMETRY



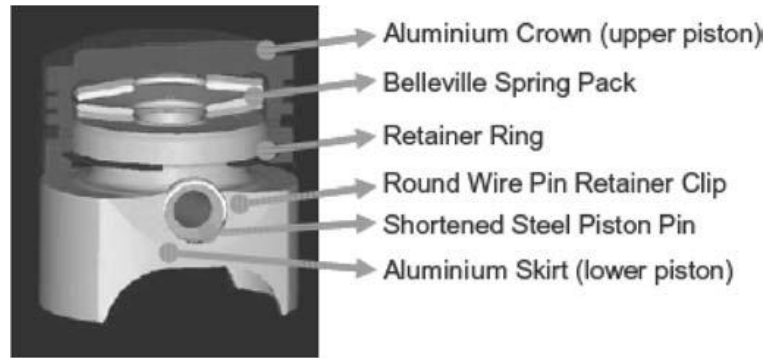
**Figure 4.** Ford VCR engine [7]



**Figure 5.** Daimler Benz VCR piston [7]

Daimler-Benz VCR piston is able to modify compression ratio by modification of height of the piston. This is the most attractive solution because requires minimum changes to the base engine architecture compared with other options. Unfortunately, it requires a significant increase in reciprocating mass and, more importantly, a means to activate the height variation within a high-speed reciprocating assembly.

The University of Michigan developed a pressure-reactive piston for spark ignition engines. The pressure-reactive piston assembly consists of a piston crown and a separate piston skirt, with a set of springs contained between them.

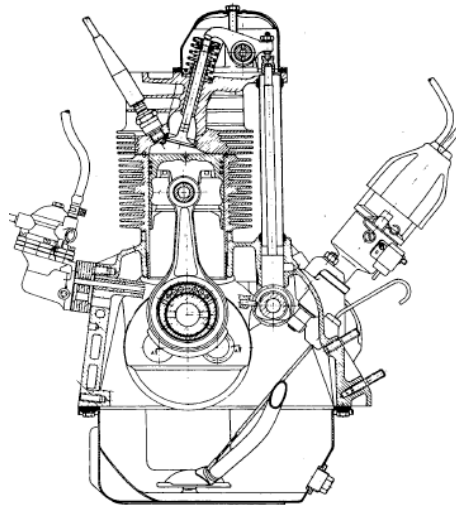


**Figure 6.** Pressure Reactive Piston Cross Section [7]

The piston crown deflects according to cylinder pressure with modifications of compression ratio. This mechanism limits peak pressure at high loads without an additional control device, allowing the engine to operate with a high compression ratio at low load conditions. It can be adapted to conventional engines with only changes of piston and connecting rod design [7].

### **ROAD ATTACHED ECCENTRIC REGARDING CRANKSHAFT**

The base engine was a small car 650 cc two cylinder engine and only one cylinder was used. The main reason to apply the VR/LE concept to SI car engines is to gain the engine efficiency at partial loads by increasing the compression ratio up to that limited by the occurrence of the knock.



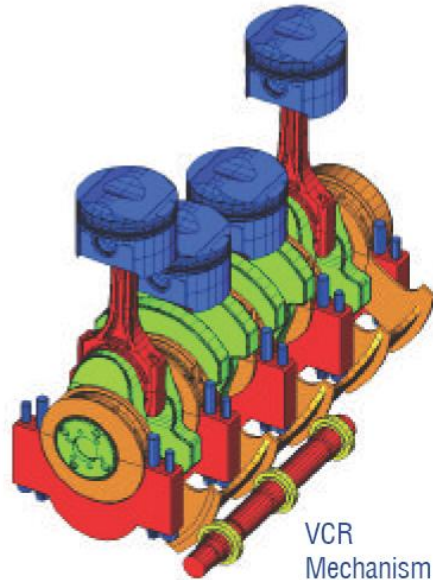
**Figure 7.** VR/LE VCR engine [8]

The engine cross-sections are presented in Figure 7. The single-cylinder crankshaft consists of three parts. Two of them are assembled together by pressing. The hand-operated regulation mechanism is mounted on the front end of the crankshaft. It has allowed for the phase angle adjustment from outside of the engine during the engine operation. The original wedge type combustion chamber has been used. It had to be lowered to increase the maximum compression ratio [8].

### **ECCENTRIC MOUNTED CRANKSHAFT**

FEV VCR engine was presented in 2007 at SAE World Congress. The concept of the engine is based upon the concept of an eccentric crankshaft bearing. Rotation of the eccentric bearing

leads to a vertical position change of the crank train relative to the cylinder head and thus, a continuous change in the compression ratio. An electric motor controls the adjustment between compression ratios of 8 and 16. The VCR element allows the engine to take advantage of the higher octane of ethanol by increasing the compression ratio for higher-level ethanol blends [9].



**Figure 8.** FEV VCR engine [9]

### **CRANK ROAD MECHANISM WITH GEARS**

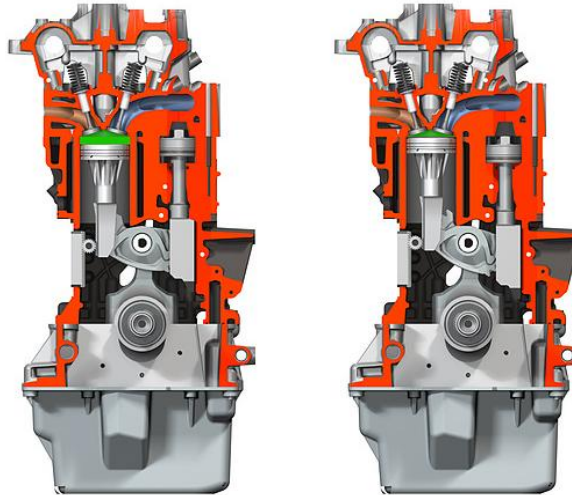
MCE-5 engine was developed in France by PSA. The engine has a cubic capacity of 1484 cm<sup>3</sup> is equipped with two-stage turbocharger, variable valve timing and a compression ratio between 6:1 and 15:1, maximum power output in 217 Hp between 4000 and 5000 rpm and maximum torque 420 Nm at 1500 rpm. The compression ratio can be varied independently for each cylinder. The combined-cycle fuel consumption was 6.7l/100 km. The variable valve timing reduces overlap in high compression mode. Compression is varied by altering the height of a secondary piston which moves vertically in a chamber parallel to the drive piston. The height is hydraulically modified, the second piston is attached to a rack which engages the teeth of a gear wheel whose pivot point is the 'small end' attached to the top bearing of the connecting rod. Gear teeth on the opposite side of the wheel engage on a second rack attached to the bottom of the drive piston. This rack has a finer rack on its opposite face, which engages a small gear wheel; the rack moves up and down against the small gear wheel transmitting the piston's motion to the crankshaft via the large gear wheel and connecting rod. As the secondary piston moves down, the large gear wheel pivots around the small end, causing the drive piston to rise in the bore, raising the compression ratio. As the secondary piston moves up, the drive piston is lowered in the bore, and the compression ratio is reduced [10].

### **ARTICULATED ROADS WITH ADDITIONAL CONNECTION BETWEEN ROAD AND CRANKSHAFT**

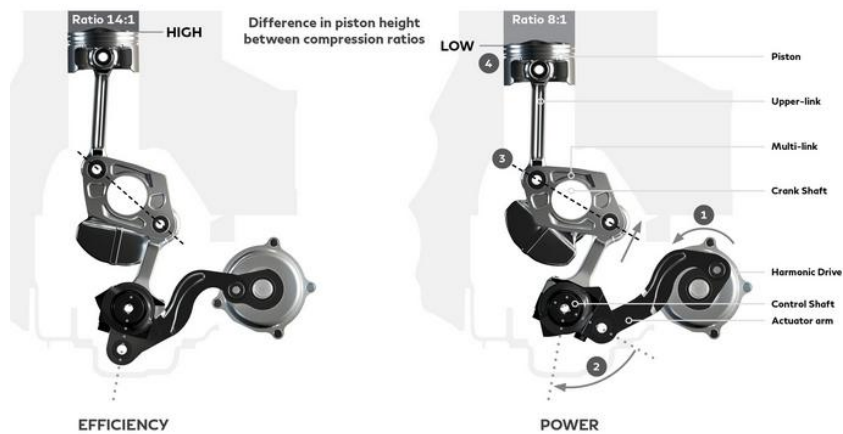
Nissan presented first production-inlet variable compression ratio gasoline engine in 2016 at Paris Motor Show. The 2.0 l 4 cylinder turbocharged VCR engine enables variation of compression ratio between 8:1 and 14:1 depending on engine load. The engine was designed

to replace 3.5l V6 engine with a target of 200 kW and 390 Nm for performances and a reduction of fuel consumption of 27%.

VCR is obtained by a multi-link system with an electric motor actuator which drives the reduction gear that moves an angled actuator arm. The arm in turn rotates a control shaft with four aligned eccentric cams, one for each cylinder. An intermediate link with bearings at each end connects the eccentric cam at the bottom end to the multi-link at the top end. The center of the multi-link runs in a bearing around the crankshaft journal. A second bearing on the multi-link, positioned 180° degrees from that connecting the intermediate link effectively serves as the piston connecting rod big-end bearing. This arrangement produces a 17° offset of the con-rod from the crankshaft journal center point.



**Figure 9.** MCE-E VCR engine [10]



**Figure 10.** Nissan VCR engine [12]

The motion described by a con-rod big end is not circular as a conventional engine is more elliptical. During the power stroke, the con-rod remain more or less vertical with reduction of side force on the piston and reduction of engine vibrations. Nissan claims the engine produce 33% less vibrations that are generated by a conventional 4 cylinder engine and no balancer shafts are required.

Engine has two fuel injection systems MPI injection for low compression and GDI for high-compression operation. Since GDI engines inherently generate high particles emissions the continuous phasing between GDI and MPI helps to reduce particle emissions. Both sets of injectors are brought into use under high load and engine speed conditions.

Forced induction is provided by a single scroll turbocharger, equipped with an electronic waste-gate actuator. The variable compression system results in a variable displacement for the engine, which varies between 1.97-l and 1.997-l [10].

## CONCLUSIONS

This paper presented the various methods to obtain a variable compression engine. A VCR engine has the major advantage that enable the engine to operate at knock limit at all engine loads which improve part-load efficiency with reduction of harmful emissions . Despite patent and experiments VCR engines are not in production yet because commercial barriers because one or more engine parts must to be redesigned. With new environmental requirements it's possible to see a VCR engine on a mass produced cars in the near future.

## REFERENCES

- [1] [https://en.wikipedia.org/wiki/Compression\\_ratio](https://en.wikipedia.org/wiki/Compression_ratio)
- [2] [https://en.wikipedia.org/wiki/Variable\\_compression\\_ratio](https://en.wikipedia.org/wiki/Variable_compression_ratio)
- [3] Gabor, A., Contributions in determining the dynamic response of the variable compression ratio engines, PhD Thesis, 2012.
- [4] Hara, V., Pandrea, N., Popa, D. Stan, M., Boncea, S., Motoare termice adaptative, Editura Universității din Pitești, 1995.
- [5] Clenci, A., Autoturism echipat cu motor cu raport de comprimare variabil, Raport de cercetare, 2003.
- [6] Miller, I., SAAB Variable Compression Motor, available online at [www.me.udel.edu/meeg425/SaabVarComp.doc](http://www.me.udel.edu/meeg425/SaabVarComp.doc), 2001.
- [7] Mahlesh, P., J., Aparna, V., K., Variable compression ratio engine – A review of future power plant for automobile, International Journal of Mechanical Engineering Research and Development (IJMERD), Volume 2, Number 1 January- September 2012.
- [8] Teodorczyk, A., Variable compression ratio engine VR/LE concept, published on Institute of Heat Engineering Warsaw in 1995.
- [9] Published at <http://freerepublic.com/focus/f-news/1818771/posts> by Red Badger in 2007.
- [10] SAE article <http://articles.sae.org/6043/> published in 2009 by John Kendall.
- [11] SAE article <http://articles.sae.org/15040/> published in 2016 by John Kendall.